

**MESSER**   
Cutting Systems

# MULTITHERM *eco* COMPACT PRODUCTIVITY

# MULTITHERM<sup>eco</sup> COMPACT PRODUCTIVITY



The user-friendly control Global Control speeds set-up and reduces errors and non-productive times.



The intelligent torch lifter SL200 for plasma allows time-saving cycles and high stroke speeds.



Multiple ALFA torches with quick nozzle change permit high productivity.



# MULTITHERM<sup>eco</sup>

## THE BENEFITS

- Compact design maximises working area but takes up minimum shop space
- positive bilateral longitudinal drives for good acceleration
- automatic setting of all gas flows for oxyfuel (OmniFlow) and plasma
- Reliable height control for longer nozzle life and high quality cuts
- symmetric wheel-housings maximise usable width
- parking space for unused torches over the wheel-housings increases cutting width with one head
- up to 4 torches for high productivity
- electrical cabinet positioned over wheel-housing so it is not exposed to heat and dust
- access to electrical cabinet from the side simplifies service and maintenance work
- Messer Hole Technology for accurate inner contours
- combination of oxyfuel and plasma gives high versatility for steels, stainless steels and Aluminium cutting
- User-friendly CNC control Global Control for quick and easy set-up
- ... and many more



The efficient design of the wheel-housing combined with positive longitudinal drives ensure high stability.

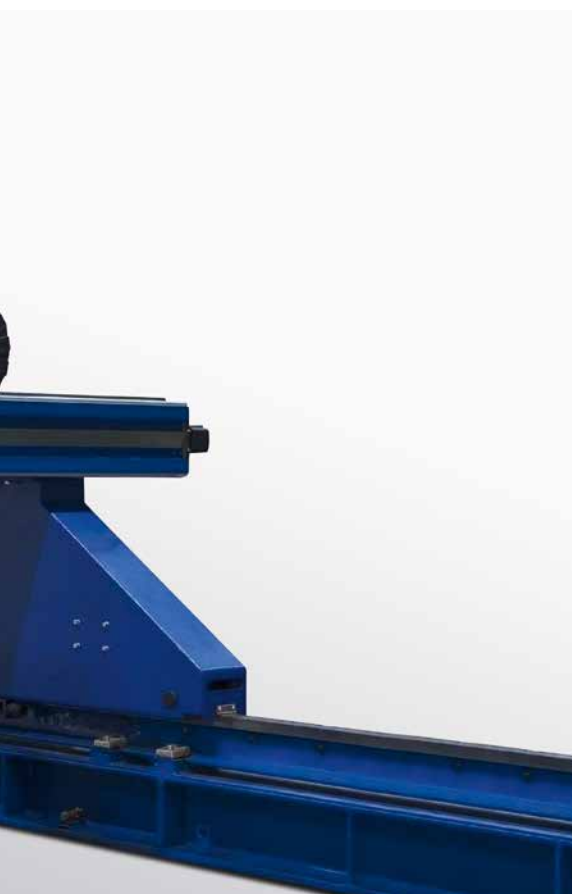

## MULTITHERM<sup>eco</sup>

### Technical Data (all dimensions in mm)

<b>A</b> Track gauge	2600	3100	3600	4000
<b>B</b> Working width*	1500	2000	2500	3000
<b>C</b> Overall width**	4070	4070	5070	5070
<b>D</b> Length	1500	1500	1500	1500
<b>E</b> Height**	1980	1980	1980	1980
<b>F</b> Track height**	500	500	500	500

\* Working widths apply for machines equipped with vertical torch units and with one tool per plate.  
When equipped with multiple tools, the working width is reduced accordingly.

\*\* The total overall dimensions depend upon equipment fitted and may vary from the above figures.

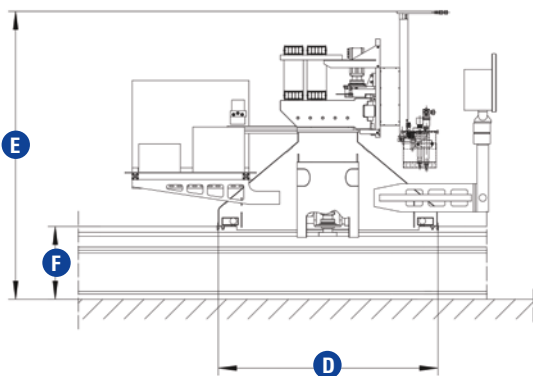
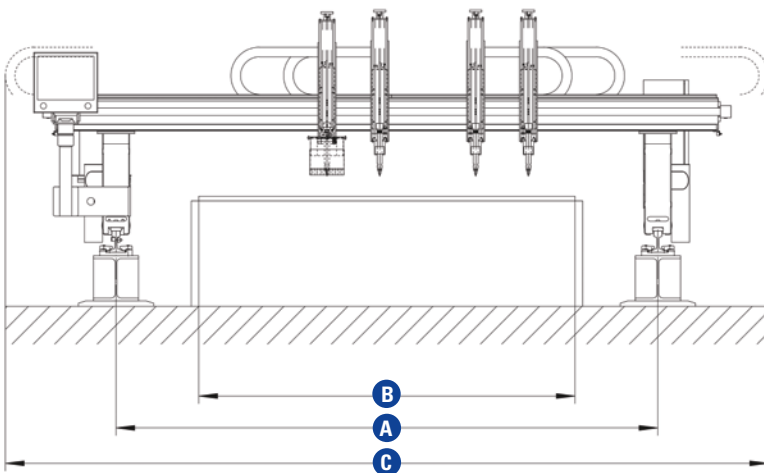

Messer Cutting Systems GmbH  
 Otto-Hahn-Strasse 2-4  
 64823 Gross-Umstadt  
 Germany  
 Tel. +49 (0) 6078 787-0  
 Fax +49 (0) 6078 787-150  
 info@messer-cs.de  
 www.messer-cs.de